



Cat[®] CP16

Padfoot Drum Vibratory Soil Compactor

The Cat[®] CP16 Vibratory Soil Compactor features a padfoot drum and is ideally suited for cohesive and semi-cohesive soil applications. A reliable propel system improves performance and efficiency and compaction technology solutions help you reach target density faster.

Efficient Power

- Built around a dual pump propel system, two pumps provide separate dedicated flow to the drum drive motor and rear axle motor for exceptional gradeability and traction in forward and reverse.
- Powered by a Cat[®] C4.4 engine that meets U.S. EPA Tier 4 Final and EU Stage V emission standards.
- Eco-mode limits engine RPM helping to reduce fuel consumption.
- Engine Idle Shutdown Timer reduces fuel burn and unnecessary idle time by shutting down the machine after a pre-set idling period.
- A variable speed cooling fan operates at the lowest possible speed for optimal cooling.
- Bolt-on leveling blade option increases machine versatility.

Exceptional Compaction Performance

- High static linear loads and amplitudes.
- Exclusive eccentric weight design provides high reliability, smooth performance and low noise.
- Automatic Speed Control and Auto-vibe functions make it easy to ensure consistent, high-quality compaction.
- The Variable Frequency option provides a wide range of frequencies to help maximize compaction performance.
- A unique oval padfoot design delivers higher weight concentration and deeper penetration for increased compaction effort. Also available in a square pad design.

Safe and Comfortable Work Environment

- A rear vision camera with large color touchscreen display enhances visibility for more complete operator control and safety.
- The pivoting seat with integrated multifunction LCD display and control console move with the operator.
- Outstanding visibility to the front and rear of machine.
- Low sound levels and vibration for greater operator comfort and productivity.
- Operators are protected from the elements by a climate-controlled ROPS/FOPS cab with hinged glass windows.

Enhance Quality and Productivity with Technology

- Get complete process control with increased coverage and more uniform compaction results using the optional exclusive semi-autonomous Command for Compaction technology to automate compaction.
- Optional Cat Compact technology helps you consistently meet compaction targets faster, more uniformly, and in fewer passes – saving on fuel and reducing rework and material costs.
 - Exclusive Machine Drive Power (MDP) is an energy-based measurement and can be used on all soil types.

Cat® CP16 Padfoot Drum Vibratory Soil Compactor

Virtually Maintenance Free

- Maintenance-free hitch with sealed-for-life bearings.
- Ground-level access to the engine compartment and cooling module for easy service and fluid sampling.
- Monitor fluid conditions with regular sampling to help extend change intervals up to 500 hours engine oil, 3000 hours eccentric housing and hydraulic oil, and 12000 hours coolant.
- Extended maintenance intervals not only reduce downtime but decrease the amount of fluid and filters that are replaced over the life of the machine.

- VisionLink® takes the guesswork out of managing your entire fleet—regardless of size or equipment manufacturer*—by providing maintenance needs, machine hours, location, fuel usage, idle time, diagnostic codes, and more through interactive dashboards on your mobile device or desktop, helping you make informed decisions that lower costs, simplify maintenance, and improve safety and security on your jobsite.

* Data field availability can vary by equipment manufacturer and is provided through an application programming interface (API).

Vibratory Soil Compactor Selection Guide

This chart helps you select which model is best suited for your work. Not all models listed are available in each region. Contact your Cat dealer representative for more information.

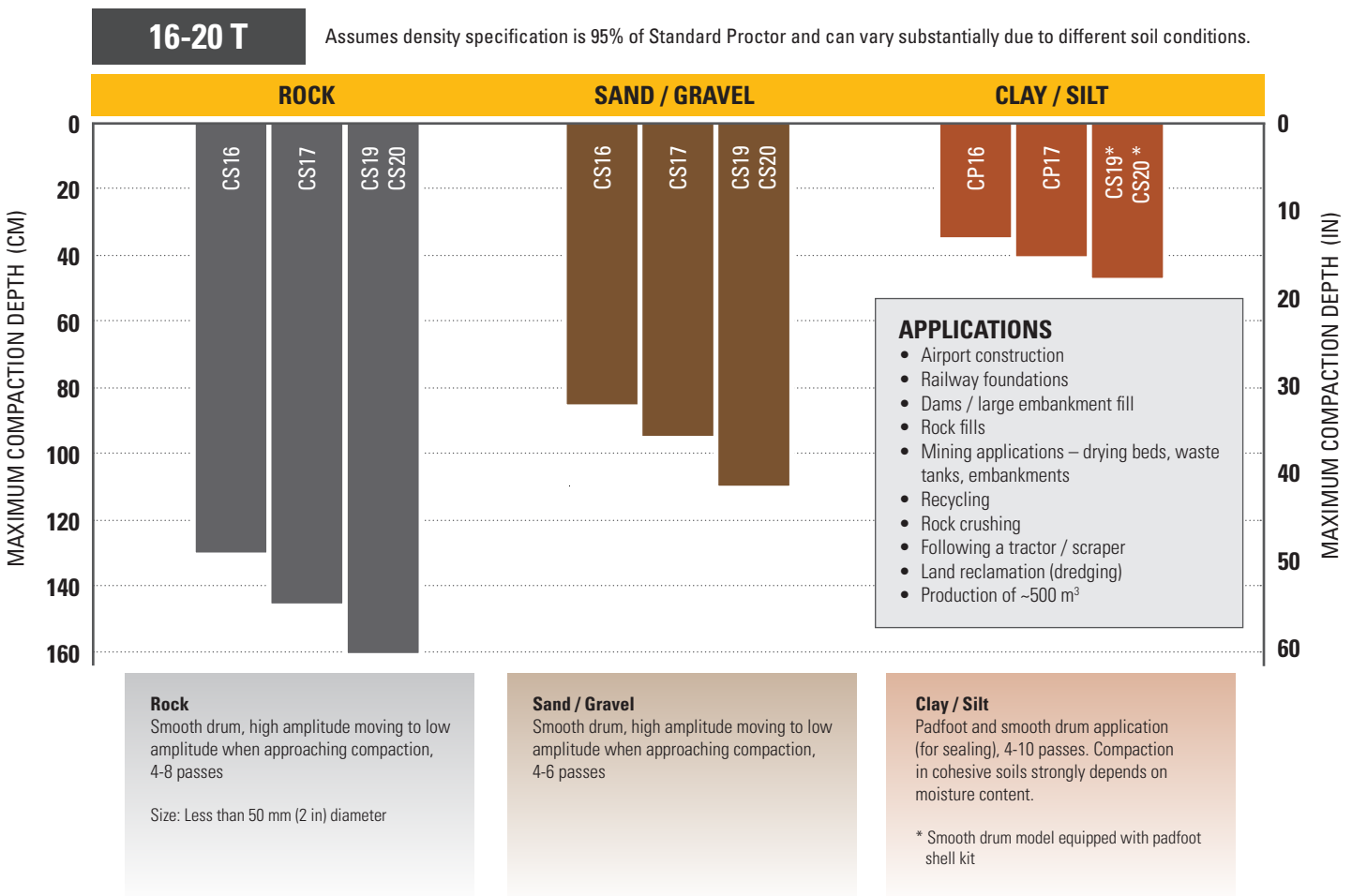

Cat® CP16 Padfoot Drum Vibratory Soil Compactor

Standard and Optional Equipment

Standard and optional equipment may vary. Consult your Cat dealer for details.

	Standard	Optional		Standard	Optional
OPERATOR ENVIRONMENT			POWERTRAIN		
ROPS/FOPS Cab with Climate Control, Cloth Seat, Exterior Rear View Mirrors	✓		Cat® C4.4 Engine	✓	
Sun Visor (Cab)		✓	Air Cleaner, Dual Element	✓	
Roll-Down Screen (Cab)		✓	Three Speed Throttle Switch including Eco-mode	✓	
Adjustable Seat with Integrated Console	✓		Automatic Speed Control (ASC)	✓	
LCD Display with Lockable Vandalism Guard	✓		Dual Propel Pumps; One for Drum Drive, One for Rear Axle	✓	
Adjustable Tilting Steering Column with Integrated Cup Holders	✓		Fuel Filter, Water Separator, Priming Pump, Water Indicator	✓	
Rear Vision Camera System with Color Touchscreen Display	✓		Tilting Radiator / Hydraulic Oil Cooler	✓	
High Visibility 50 mm (2 in) Seat Belt	✓		Dual Braking System	✓	
High Visibility 76 mm (3 in) Seat Belt		✓	Two-Speed Hydrostatic Transmission	✓	
12-volt Power Outlet	✓		Limited Slip Differential	✓	
Horn, Backup Alarm	✓		Transmission Guard		✓
VIBRATORY SYSTEM			ELECTRICAL		
Padfoot Drum – Oval or Square Pads	✓		24 volt Electrical System	✓	
Pod-Style Eccentric Weight Housings	✓		100 ampere Alternator	✓	
Dual Amplitude, Single Frequency	✓		750 Cold-cranking Amps Battery Capacity	✓	
Variable Frequency		✓	OTHER		
Auto-vibe Function	✓		Lockable Engine Enclosure, Hydraulic and Fuel Tanks	✓	
Dual Adjustable Steel Scrapers	✓		Sight Gauges for Hydraulic Oil Level and Radiator Coolant Level	✓	
Leveling Blade		✓	S•O•S SM Sampling Values: Engine Oil, Hydraulic Oil, and Coolant	✓	
TECHNOLOGY SOLUTIONS			Factory Filled Bio-Hydraulic Oil		✓
VisionLink®	✓		Halogen Working Lights (4)	✓	
Measure – Machine Drive Power (MDP)		✓	Halogen Working Lights (8)		✓
Command for Compaction		✓	LED Working Lights (8)		✓
			Amber Rotating Beacon		✓

Cat® CP16 Padfoot Drum Vibratory Soil Compactor

Technical Specifications

Engine and Powertrain

Engine Model	Cat C4.4	
Emissions	U.S. EPA Tier 4 Final, EU Stage V	
Engine Power – ISO 14396:2002	129.4 kW	173.5 hp
Gross Power – SAE J1995:2014	130.4 kW	174.9 hp
Net Power – ISO 9249:2007*	108.7 kW	145.8 hp
Net Power – SAE J1349:2011*	108.2 kW	145.1 hp
Number of Cylinders	4	
Displacement	4.4 L	268.5 in ³
Stroke	127 mm	5 in
Bore	105 mm	4.1 in
Max. Travel Speed (Forward or Reverse)	11.4 km/h	7.1 mph
Theoretical Gradeability, with or without vibration**	59%	

* Net power advertised is the power available at the engine flywheel when equipped with a fan at maximum speed, air cleaner, clean emissions module, and alternator.

** Actual gradeability may vary based on site conditions and machine configuration. Refer to the Operation and Maintenance Manual for more information.

Vibratory System

Frequency		
Standard	28 Hz	1680 vpm
During Eco-mode Operation	25.5 Hz	1527 vpm
Optional Variable Frequency	23.3-28 Hz	1400-1680 vpm
Nominal Amplitude @ 28.0 Hz (1680 vpm)		
High	2.1 mm	0.083 in
Low	0.98 mm	0.039 in
Centrifugal Force @ 28.0 Hz (1680 vpm)		
Maximum	335 kN	75,234 lb
Minimum	156 kN	35,163 lb
VM Class at High Amplitude (Cab Configuration)	VM5	

Weights

Operating Weight

ROPS/FOPS Cab		
Oval Padfoot Drum	16 339 kg	36,022 lb
Oval Padfoot Drum and Leveling Blade	17 025 kg	37,533 lb
Square Padfoot Drum	16 371 kg	36,093 lb
Square Padfoot Drum and Leveling Blade	17 056 kg	37,603 lb

Weight at Drum

ROPS/FOPS Cab		
Oval Padfoot Drum	10 576 kg	23,315 lb
Oval Padfoot Drum and Leveling Blade	11 552 kg	25,468 lb
Square Padfoot Drum	10 608 kg	23,386 lb
Square Padfoot Drum and Leveling Blade	11 584 kg	25,538 lb

Operating weights are approximate and consider full fluids, 75 kg (165 lb) operator, cab with heat and air conditioning.

Service Refill Capacities

Fuel Tank	307 L	81.1 gal
Diesel Exhaust Fluid (DEF) Tank	19 L	5 gal
Cooling System	28.2 L	7.4 gal
Heating System	1.2 L	0.3 gal
Engine Oil with Filter	11.6 L	3.1 gal
Eccentric Weight Housings (combined)	26 L	6.9 gal
Axle and Final Drives	24 L	6.3 gal
Hydraulic Tank	50 L	13.2 gal

Cat® CP16 Padfoot Drum Vibratory Soil Compactor

Technical Specifications

Dimensions

1A	Overall Length	6.1 m	19.9 ft
1B	Optional Leveling Blade	6.6 m	21.5 ft
2A	Overall Width	2.3 m	7.7 ft
2B	Optional Leveling Blade	2.5 m	8.2 ft
3	Drum Width	2134 mm	84 in
4	Drum Shell Thickness	40 mm	1.6 in
5	Drum Diameter		
	Over Oval Pads	1549 mm	61 in
	Over Square Pads	1495 mm	58.9 in
6	Overall Height	3.1 m	10.2 ft
7	Wheelbase	2.9 m	9.5 ft
8	Ground Clearance	438 mm	17.2 in
9	Curb Clearance	497 mm	19.6 in
10	Optional Leveling Blade Height	683 mm	26.9 in
	Inside Turning Radius	3.7 m	12.1 ft
	Hitch Articulation Angle	34°	
	Hitch Oscillation Angle	15°	

Padfoot Drum

	Number of Pads	140	
	Number of Chevrons	14	
	Oval Pads		
	Pad Height	127 mm	5 in
	Pad Face Area	74.4 cm ²	11.5 in ²
	Square Pads		
	Pad Height	100 mm	3.9 in
	Pad Face Area	123.1 cm ²	19.1 in ²

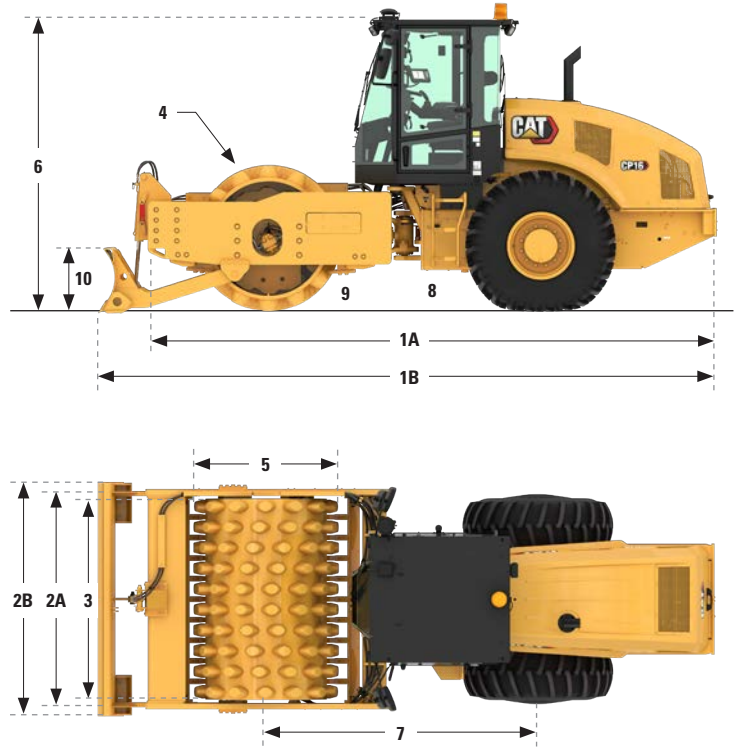

Cat® CP16 Padfoot Drum Vibratory Soil Compactor

Environmental Declaration

The following information applies to the machine at the time of final manufacture as configured for sale in the regions covered in this document. The content of this declaration is valid as of the date issued; however, content related to machine features and specifications are subject to change without notice. For additional information, please see the machine's Operation and Maintenance Manual.

For more information on sustainability in action and our progress, please visit www.caterpillar.com/en/company/sustainability.html.

ENGINE

- The Cat C4.4 is available in configurations that meet U.S. EPA Tier 4 Final and EU Stage V emissions standards.
- Cat diesel engines are required to use ULSD (ultra-low sulfur diesel fuel with 15 ppm of sulfur or less) or ULSD blended with the following lower-carbon intensity fuels* up to:
 - ✓ 20% biodiesel FAME (fatty acid methyl ester)
 - ✓ 100% renewable diesel, HVO (hydrotreated vegetable oil) and GTL (gas-to-liquid) fuels

Refer to guidelines for successful application. Please consult your Cat dealer or "Caterpillar Machine Fluids Recommendations" (SEBU6250) for details.

**Tailpipe greenhouse gas emissions from lower-carbon intensity fuels are essentially the same as traditional fuels.*

AIR CONDITIONING SYSTEM

The air conditioning system on this machine contains the fluorinated greenhouse gas refrigerant R134a (Global Warming Potential = 1430). The system contains 0.8 kg (1.8 lb) of refrigerant, which has a CO₂ equivalent of 1.144 metric tonnes (1.261 tons).

PAINT

- Based on best available knowledge, the maximum allowable concentration, measured in parts per million (PPM), of the following heavy metals in paint are:
 - Barium < 0.01%
 - Cadmium < 0.01%
 - Chromium < 0.01%
 - Lead < 0.01%

SOUND PERFORMANCE

With cooling fan speed at maximum value:

Operator Sound Pressure Level (ISO 6396:2008) – 81 dB(A)
Exterior Sound Power Level (ISO 6395:2008) – 109 dB(A)

- When properly installed and maintained, the cab offered by Caterpillar, when tested with doors and windows closed according to ANSI/SAE J1166 OCT98, meets OSHA and MSHA requirements for operator sound exposure limits in effect at time of manufacture.
- Hearing protection may be needed when operating with an open operator station and cab (when not properly maintained or doors/windows open) for extended periods or in a noisy environment.

OILS AND FLUIDS

- Caterpillar factory fills with ethylene glycol coolants. Cat Diesel Engine Antifreeze/Coolant (DEAC) and Cat Extended Life Coolant (ELC) can be recycled. Consult your Cat dealer for more information.
- Cat BIO HYDRO™ Advanced is an EU Ecolabel approved biodegradable hydraulic oil.
- Additional fluids are likely to be present, please consult the Operations and Maintenance Manual or the Application and Installation guide for complete fluid recommendations and maintenance intervals.

FEATURES AND TECHNOLOGY

- The following features and technology may contribute to fuel savings and/or carbon reduction. Features may vary. Consult your Cat dealer for details.
 - Standard Eco-mode limits engine RPM, lowering overall fuel consumption
 - Optional compaction control technology reduces unnecessary passes, increasing operating efficiency
 - Extended maintenance intervals reduce fluid and filter consumption
 - Engine Idle Shutdown Timer reduces unproductive hours and fuel burned
 - Variable speed cooling fan operates at the lowest speed for optimal cooling

RECYCLING

- The materials included in machines are categorized as below with approximate weight percentage. Because of variations of product configurations, the following values in the table may vary.

Material Type	Weight Percentage
Steel	81.81%
Iron	10.93%
Nonferrous Metal	0.97%
Mixed Metal	0.19%
Mixed-Metal and Nonmetal	0.37%
Plastic	0.79%
Rubber	2.15%
Mixed Nonmetallic	0.00%
Fluid	0.99%
Lead (Batteries)	0.30%
Other	0.90%
Uncategorized	0.60%
Total	100%

- A machine with higher recyclability rate will ensure more efficient usage of valuable natural resources and enhance End-of-Life value of the product. According to ISO 16714 (Earthmoving machinery – Recyclability and recoverability – Terminology and calculation method), recyclability rate is defined as percentage by mass (mass fraction in percent) of the new machine potentially able to be recycled, reused or both.

All parts in the bill of material are first evaluated by component type based on a list of components defined by the ISO 16714 and Japan CEMA (Construction Equipment Manufacturers Association) standards. Remaining parts are further evaluated for recyclability based on material type.

Because of variations of product configurations, the following value in the table may vary.

Recyclability – 97%

Cat® CP16 Padfoot Drum Vibratory Soil Compactor

For more complete information on Cat products, dealer services, and industry solutions, visit us on the web at www.cat.com

© 2023 Caterpillar
All rights reserved

Materials and specifications are subject to change without notice. Featured machines in photos may include additional equipment.
See your Cat dealer for available options.

CAT, CATERPILLAR, LET'S DO THE WORK, their respective logos, "Caterpillar Corporate Yellow," the "Power Edge" and Cat "Modern Hex" trade dress as well as corporate and product identity used herein, are trademarks of Caterpillar and may not be used without permission.

VisionLink is a trademark of Caterpillar Inc., registered in the United States and in other countries.

QEHO3083 (11-2023)
Build Number: 03A
(U.S. EPA Tier 4 Final, EU Stage V)

